

InVision UNIVERSAL PANEL MOUNT DIGITAL DASH



For mounting in flat panel dashes



What is Included:

- (1) Preassembled Panel Mount Digital Gauge Display & Universal Wire Harness
- (1) Oil pressure Sending Unit
- (1) Temperature Sending Unit
- (2) Display mounting Brackets
- (1) Selector Knob Mounting Bracket

Recommended Tools & Supplies:

- Screwdriver set (including both flathead & Phillips)
- 1/4" drive standard & metric socket set
- 3/8" drive standard & metric socket set
- Standard & Metric open end wrenches
- Wire strippers
- Wire crimpers
- Wire splice connectors for connecting wires to your vehicle harness.
- Wire coverings or zip ties for neatly organizing or bundling wires.
- Wire diagram of your vehicle
- 3A & 5A fuse & fuse holders
- Soldering iron, solder & various sizes of heat shrink tubing
- Digital volt/ohm meter

Step 1, Panel Prep

You will need a flat panel, 0.06-0.125" thick, that has 13.25" x 5.60" space available for the display. Selector knob will need 1.20" x 2.30". Remote mounting of the selector knob is possible.

The display and the selector knob insert from the front of the panel. The tabs on display indicate the bottom of the display.

Please see panel cutout drawing and layout dimension drawings for more details.

Step 2, Wiring:

Although the InVision Digital Dash comes assembled, the wiring will take a little time, therefore it is easier to disconnect the wire harness from the rear of the InVision Digital Dash. Push down on the blue locking tab, so that you can pull the pink latch all the way up, and over as shown in the pictures below. The connector will then easily pull out. When you are ready to reinstall the wire harness, follow the steps in reverse order, except that you won't have to push the locking tab to install (you will need to secure the pink latch).

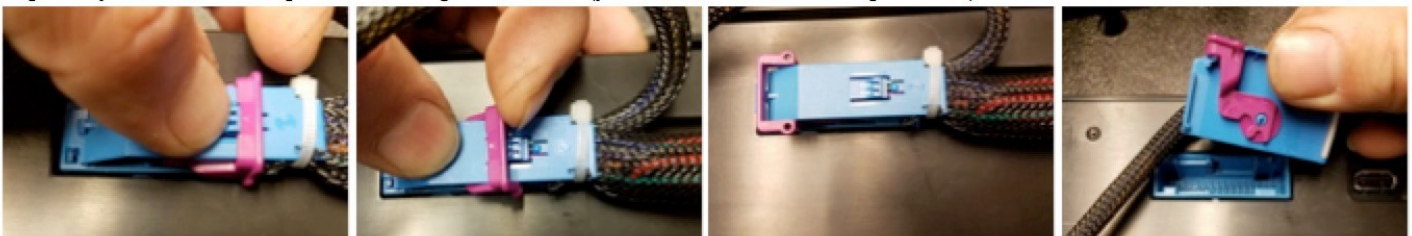

You can then remove the Selector Knob from the rear of the selector knob panel by removing the two T10 Torx screws. Now you can move the InVision Digital Dash out of the way so that you have plenty of room to work.

Wiring will require some basic automotive electrical knowledge, and in some cases a vehicle specific wiring diagram, or the ability to test circuits to verify proper hook ups. You will need to be able to test various circuits at this time. You will find the following wire colors on your new InVision Digital Dash. There are several different methods of connection that you can use when connecting the InVision Digital Dash wire harness to your existing wiring:

Gray: Dash Lights. Connect to factory dash lighting wire. Look for a power that turns on and off with the parking lights and or head lights, but also dims (power lowers) as you adjust your headlight dimmer. A test light works well for checking this. If by chance you have a faulty dimming circuit in your vehicle, you can use any of the wires from your headlight switch that turn on & off with the park lights. The factory dimmer is not used by the InVision Digital Dash. There is more on the functionality of this later in step 4 of the instructions.

Red (4 foot): 12v, key on power. Connect to the factory gauges power only if it is 12v. This power should turn on and off with the ignition switch. If there is no factory wire to use, you might find an ignition power from the fuse box, or from the ignition switch. This should be protected with a standard automotive 5A inline fuse.

Pink: Battery power, for memory retention. You should connect this to any constant-on, battery power such as at the factory fuse box, the ignition switch, or directly to the battery. Check for power at these locations by leaving the key switched off, and using your test light to locate power that is still on. This should be protected with a standard automotive 3A inline fuse.

Black (4 foot): System ground. We recommend you choose a new ground location for this wire, preferably at the engine. You can ground to the rear of one of the cylinder heads, or on the intake manifold to one of the unused accessory bolt holes. We do NOT recommend using existing, factory cluster ground as this is going to be a much older circuit, which may no longer be a very clean ground.

Green w/ red stripe: Hi Beam indicator. Connect to the factory hi beam indicator wire or to the hi beam switch. This circuit will be powered only when the headlights are on, and the high beams are on.

Blue w/ white stripe: Left turn indicator. Connect to the factory left turn indicator wire. You can test for this with a test light. Turn the key on, and then the left turn signal on. Look for the wire that flashes your test light with the turn signal.

Blue w/ red stripe: Right turn indicator. Connect to the factory right turn indicator wire. You may test for this with a test light Turn the key on, and then the right turn signal on. Look for the wire that flashes your test light with the turn signal.

Red (2 foot): 12v key on power. This is intended for applications where you might be using a 3-wire vehicle speed sensor that requires power. You should find that this wire is powered any time that the InVision Digital Dash is powered. You can also use this to power a GPS interface module, or some other accessory as desired as long as it fits within the recommended fuse requirements.

Green w/ white stripe: Temperature sender wire. Run this out to the engine bay, to where you will install the Auto Meter temperature sender.

Violet: Speed signal. Connect this to the signal wire at your speed sender/sensor. If you are using a computer (ECM, PCM, ECU, etc.), you can connect this to the factory speed signal wire at the computer instead of the speed sensor if it is equipped. Consult a diagram for your computer to verify.

Brown: Oil PSI sender wire. Run this out to the engine bay, to where you will install the Auto Meter oil pressure sender.

Green: Tachometer signal wire. Where you connect this wire will depend on what ignition system you have. If your engine is distributor equipped, with no ignition box, you can connect to the negative side of the ignition coil. If you are using an aftermarket ignition box, you will connect the green wire to the dedicated tachometer signal output wire and NOT to the ignition coil. If your application has no distributor or ignition box and is using coil packs you might have an available tachometer signal at your computer. If you have questions on this, please call AutoMeter Tech Support at (866)-248-6357.

Black (2 foot): Speed Sensor/Sender Ground. This is used only if you have a speed sensor/sender that requires a supplied ground. If you have a speed sensor that is already existing/functioning that is already grounded or is grounded by a computer, then this wire is not needed. If you need to supply ground to your speed sender/sensor, then connect this black wire to the ground wire of your speed sender/sensor.

Orange: Fuel sender wire. Connect to the original fuel sender wire. GM typically used tan, pink, or violet for this. To be sure, you may use a digital ohm meter to test which wire is correct. To determine the correct wire, set your ohm meter to its lowest setting (most commonly 200, with no K or M suffix). Connect the positive lead of the meter to the wire you are going to test. Ground the meters negative lead. You are looking for something that resembles the fuel level reading you had before removing the original dash. For example, the factory sender is 0 to 90 ohms. If the tank was at or near E, you might see 0 to 4 ohms. If the tank was at half tank, the reading should be about 45 ohms. If the tank was at Full, the reading should be near 90 ohms. The fuel level sender simply varies from 0 to 90 based on the amount of fuel there is in the tank. If the factory fuel gauge did NOT function, you may have further diagnosis to do to test the sender in the tank, the sender ground, and the sender wire itself. Call AutoMeter Tech Support at (866)-248-6357 if further assistance is needed.

Brown w/ white stripe: Service Engine Soon Indicator. Not all applications will use this. This is only used if you are using an engine management system that has a grounded output for a Service Engine Soon light. This warning light can be used for any grounded output warning.

Six pin Connector. For future expansion.



Now is a good time to plug your harness into the new dash display, and turn power on to make sure all of your wiring is good, and to become familiar with the dash. Remember you still have senders to connect outside of the interior at this point.

We will cover Set Up details later, though for now, simply make sure that your dash powers up, and that turn signals, and hi beam indicator (when lights are on) function.

Install the new Panel Mount Digital Dash & Selector Knob Panel into place using the supplied brackets. Re-install the Selector Knob making sure thread bracket over the cable before attaching the selector knob to the panel. Then secure the bracket.

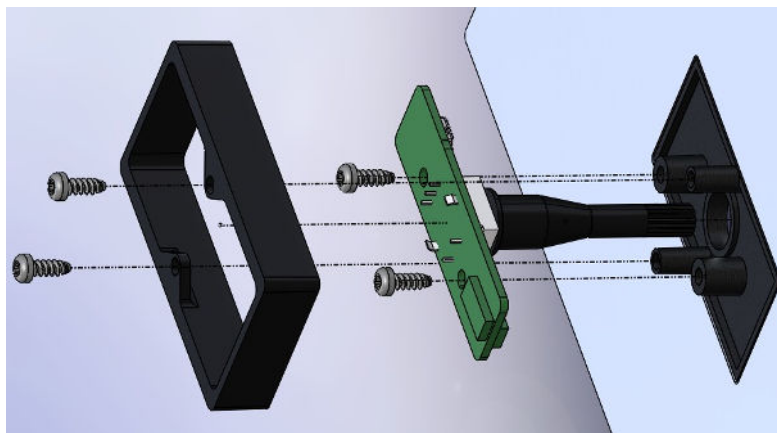
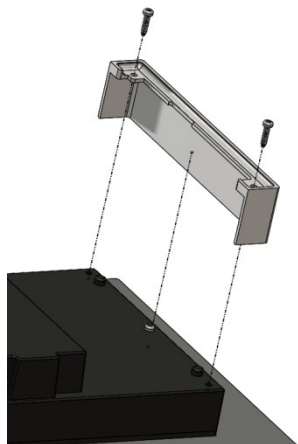

Step 3, Senders:

Water temperature: The InVision Digital Dash must use the included AutoMeter temperature sender. We recommend whenever possible to install the sender into the cylinder head. On a V8, install the sender into the driver's bank cylinder head. If you can't use this location, you can use the intake manifold temperature sender hole. The sender is 1/8" NPT, and includes a 3/8" & 1/2" adaptor bushing.

If you are running a GM LS based engine, you will need a different sender & adapter due to the LS engine family unique size of 12mm x 1.5. You will need Auto Meter model number 2259 sender & model number 2277 adapter. This will install into the passenger bank cylinder head, just past the last exhaust port.

You may now connect the Green w/ white stripe sender wire from the InVision Digital Dash wire harness.

Oil Pressure: The InVision Digital Dash must use the included Auto Meter pressure sender. If you choose to mount the sender at the rear of the engine on a small block Chevy, near the distributor, you may use a 1-1/2" long, 1/8"NPT pipe nipple (double male straight) & 1/8"NPT 45 degree elbow fitting to raise the sender above the edge of the intake, and tilt out of the way of the distributor. The sender is 1/8" NPT, and includes a 3/8" & 1/2" adaptor bushing.

If you are running a GM LS based engine, you may need a different adapter due to the LS engine family unique size of 16mm x 1.5 located at the back of the engine. You will need Auto Meter model number 2268 adapter. Another popular option is to modify the cover plate located just above the oil filter, and drill & tap a 1/8"NPT hole and install the sender there. Some choose to run braided line, such as Auto Meter model number 3227, in order to remotely mount the sender away from the exhaust when using this location/method.

Fuel Level: This kit is designed for multiple factory fuel senders. The resistance ranges that are compatible are: 0-90, 240-33, 73-10 (linear), 73-10 (non-linear), 16-158, 40-250, and 0-30 OHM. If you have a fuel sending unit other than those listed you will need to change the fuel sender.

Speed Sensor/Sender: This sender was not included with the InVision Digital Dash, since many users already have an existing speed sender due to using a late model drivetrain, or having a pre-existing electric speedometer.

You can use Auto Meter model number 5291 speed sender. Connect the red wire from the speed sender to the 2 foot red from the InVision Digital Dash wire harness. Connect the black speed sender wire to the 2 foot black wire from the InVision Digital Dash wire harness. Connect the white speed sender wire to the violet wire from the InVision Digital Dash wire harness.

If you have a pre-existing 2-wire speed sender that was being used for an electric speedometer, you may connect one wire of this speed sender to the 2 foot black wire from the InVision Digital Dash wire harness. Then connect the other wire of the speed sender to the violet wire from the InVision Digital Dash wire harness. Many times the polarity of the 2 wire speed sender is not polarity sensitive. Though if you have a black wire, that one is typically ground, and the other (white, tan, violet, green, etc.) is typically signal. If both were the same color, then it will not matter.

If you are using a factory late model drivetrain which uses its own speed sender, you will then use the factory speed-out wire/circuit.

** If your vehicle is factory TBI, your computer will depend on having the proper speed signal which would have originally been part of the original cluster. This is commonly a 2 pulse per revolution, Hall Effect (square wave) speed signal. You can obtain the proper speed sender through from speed sender suppliers (call AutoMeter Tech Support at (866)-248-6357 for a recommendation if needed). The speed sender will then have to get wired to both the InVision Digital Dash, as well as the original speed sender wire going back to the vehicles computer. Without this speed signal going to the computer, you will have a service engine light on, a stored fault code, and possible drivability issues as a result.

Start the engine: Check to make sure you are registering oil pressure, water temperature (as it warms up), volts, fuel level, and RPM. You will need to calibrate & drive the vehicle for speedometer function. Also check for any leaks at this time.

Step 4, Setup:

The InVision Digital Dash comes equipped with a button/knob referred to as the “Selector Knob”. To enter the InVision Digital Dash Main Menu, push in & release the Selector Knob one time. The Main Menu will appear. The Selector Knob also turns slightly left or right. Use the left or right motion to scroll through the menu. Think of pushing in & releasing the knob as an “Enter” command.

If you attempt to enter the menu while driving (vehicle in motion), you will only get a partial menu. In order to access the full menu, the power needs to be on, but you need to be stopped (the engine can be running). The full Menu shown is in the below pictures.



Warnings: The InVision Digital Dash provides audible and visual warnings for certain parameters. Warnings are only active when the engine is running.

The fuel level warning is not adjustable, and comes pre-set at around 1/8 tank. You can disable the warning if you choose.

The oil pressure warning can be adjusted to turn on at 4, 8, or 18 PSI. You can disable the warning if you choose.

The water temperature warning can be adjusted to turn on at 220, 235, or 250 degrees. You can disable the warning if you choose.

The voltmeter warning can be adjusted to turn on at 11.5, 12.2, or 15.0 volts. You can disable the warning if you choose.

To adjust, or disable a warning, enter the Main Menu and scroll to the gauge you want to adjust (we will show oil pressure here), and press Enter. Scroll to the value you want to select, and press Enter. To exit, scroll up to Back and press Enter.



Once you are finished adjusting your warnings, and you are back at the Main Menu, scroll to the top until Close is highlighted, and press Enter.

Tachometer PPR (Pulse Calibration): This is the tachometer calibration. PPR stands for pulses per revolution. A standard V8 with a distributor type ignition system will be 4ppr. This is also the standard setting for the InVision Digital Dash. If you have an in line 6, your setting would be 3ppr. And if you have updated your drivetrain to an LS type engine and are using a factory PCM, the PCM tachometer output is 2ppr.

To adjust PPR, enter the Main Menu. Scroll to Tachometer, and press Enter. Next, scroll to Pulse Calibration, and press Enter.



Once you have chosen the correct PPR, scroll up to Back, and press Enter. Then, scroll up to Back again, and press Enter. Once you are back at the Main Menu, scroll to Close and press Enter.

Tachometer Scaling: The standard scale is 0-10,000 RPM. You can adjust the tachometer scale to be 0-8,000 RPM if desired. To adjust the scaling, enter the Main Menu. Scroll to Tachometer, and press Enter. Next, scroll to RPM and press Enter. Scroll to the desired scale, and press Enter.



Once you have chosen the Tachometer Scaling, scroll up to Back, and press Enter. Then, scroll up to Back again and press Enter. Once you are back at the Main Menu, scroll to Close and press Enter.

Speedometer Calibration: Speedometer calibration will be required for an accurate speedometer reading. You will need a 2 mile pre-marked distance.

To calibrate the speedometer, enter the Main Menu, scroll to Speedometer and press Enter. Next, scroll to Speed Calibration, and press Enter.

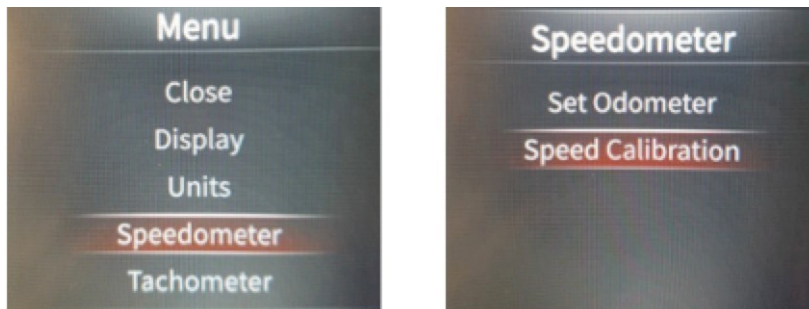

Drive to the beginning of your 2 mile distance (this could be at your driveway or elsewhere). Choose Start Calibration and press Enter. The display will now show "Stop Calibration" (don't press Enter yet). Drive 2 miles and come to a stop. Press Enter on Stop Calibration. You don't have to come to a complete stop when pressing Stop Calibration, but it helps to insure that you have a more accurate 2 mile distance. The more accurate your 2 miles are, the more accurate your speedometer will be.

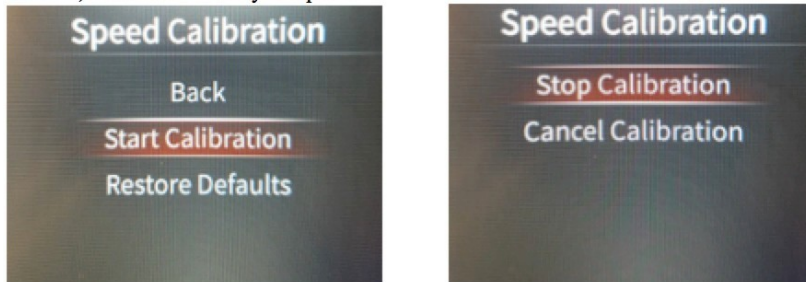

If the speed sender/sensor is functioning, and your calibration is successful, you can scroll up to Back and press Enter. Then, scroll up to Back again and press Enter. Once you are back at the Main Menu, scroll to Close and press Enter.



Time: You can choose to display the time in either 12 hour (standard) or 24 hour mode.

To adjust the time, enter the Main Menu, scroll to Time, and press Enter. Select either 12 or 24 hour mode, and press Enter. You can also adjust the time here. After you select the mode, scroll to the hours (left) segments and click Enter. Scroll the numbers up or down by turning the Selector Knob left or right. Press Enter, and scroll to the right to highlight the minutes (right) segments. Scroll the numbers up or down by turning the Selector Knob left or right. Press Enter. Once you are finished, scroll to "OK" and press Enter. This returns you to the Main Menu.

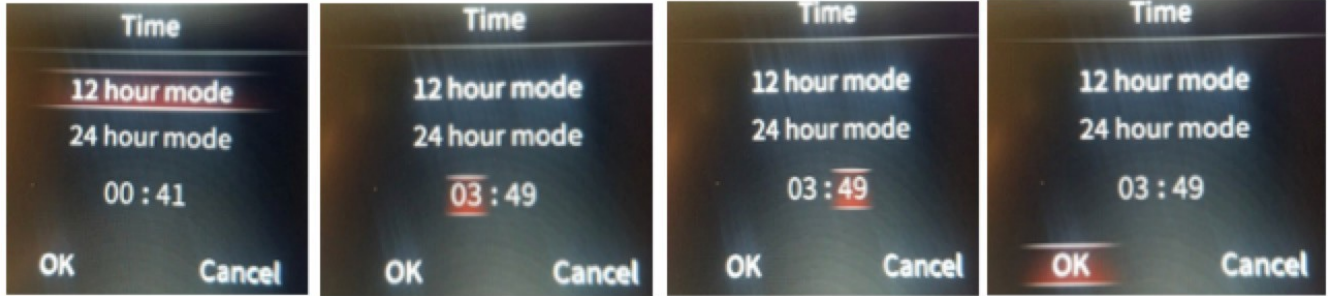

Fuel Sensor: You have 7 different fuel sensor ranges to select from, select the one that matches your vehicles fuel sender and press enter. Once you have chosen the correct sensor range, scroll up to Back, and press Enter. Once you are back at the Main Menu, scroll to Close and press Enter.

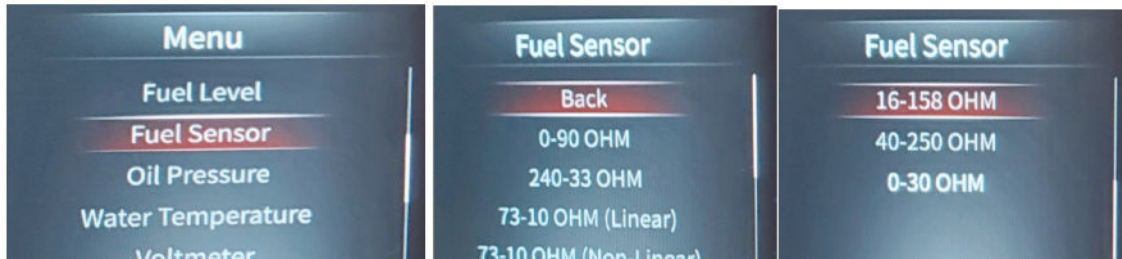

Display: You have 3 different display styles to choose from. To choose the display style, enter the Main Menu, scroll to Display, and press Enter. Then scroll to the display number you want, and press Enter. The display you choose will be displayed.

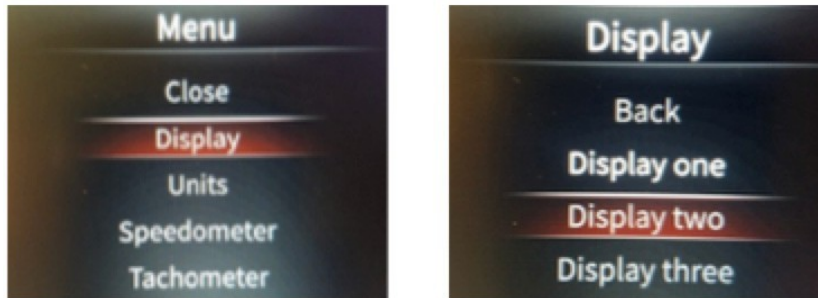

Display One



Display Two



Display Three



Display Four

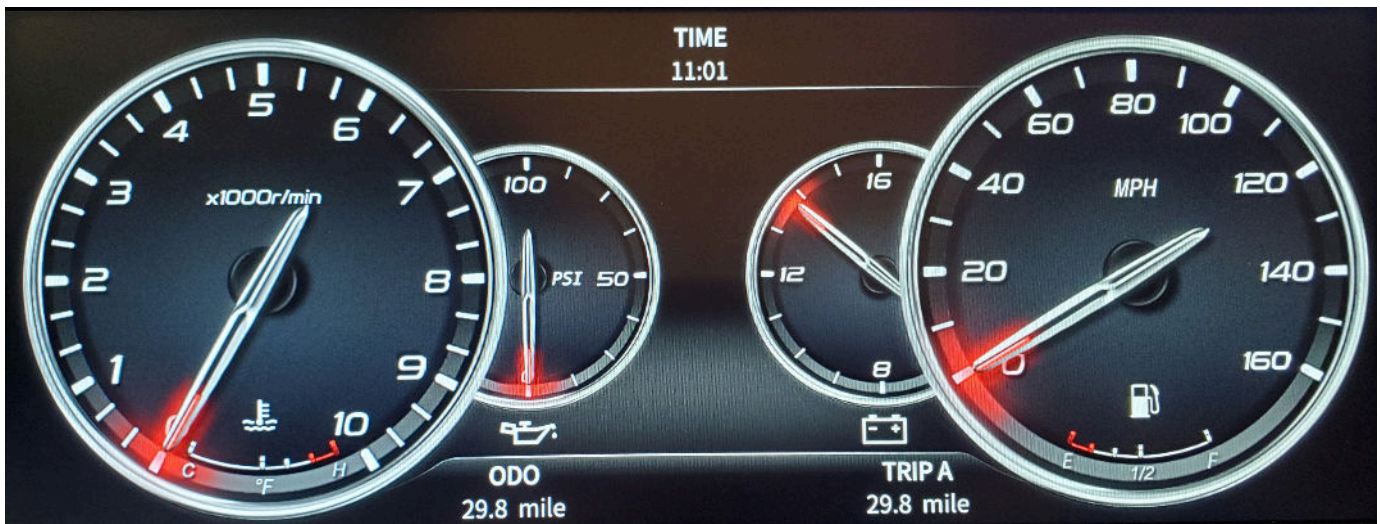

Displays One, Two, and Four do not have any color options. If you choose Display Three, you will have a choice of colors. To change the color, when Display Three is displayed, press Enter to access the Main Menu, scroll to Display and press Enter. Scroll to Display Three (which will be in old white) and press Enter again. The Display Three color options menu will come up (there are two pages of color options). Scroll to the desired color and press Enter.



To Exit, scroll up to Back, and press Enter. Then, scroll up to Back again and press Enter. Once you are back at the Main Menu, scroll to Close and press Enter.

rightness: You will no longer adjust brightness with the factory dash light dimmer. You will select Daytime and Nighttime brightness for the InVision Digital Dash. Once power is applied from the lighting to the InVision Digital Dash, it will automatically dim down to the Nighttime rightness you have selected. To adjust the brightness, enter the Main Menu, scroll down until you reach Brightness, and press Enter. Scroll down one time for Daytime settings and press Enter. Scroll left or right to choose the percentage of brightness. When you are satisfied, press Enter then scroll down one time again for Nighttime and press Enter. Scroll left or right for the percentage of brightness desired. When adjusting Nighttime brightness, you should have the vehicles lights turned on. When you are satisfied, press Enter, then scroll up to Back, and press Enter. Scroll up to Close and press Enter to exit the Main Menu.

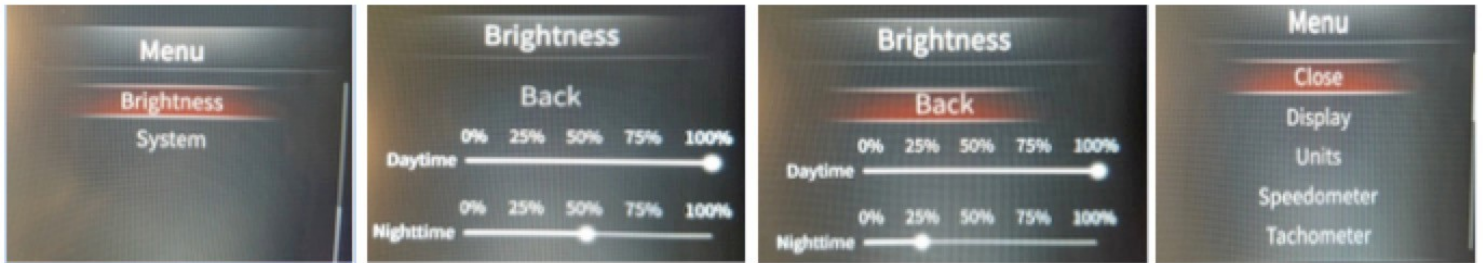

The odometer can be set to match the mileage on your vehicle. This can only be done ONE time only, and must be done within the first 500 miles. After being set, or 500 miles have been accumulated, this option will disappear and it cannot be set again.

To set your odometer, enter the Main Menu, scroll to Speedometer, and push Enter. Scroll down to Set Odometer and press Enter. Scroll down to the odometer digits. When you get to the digit that you want to change, press Enter, then scroll up or down with the Selector Knob until you get to the desired number and press Enter.

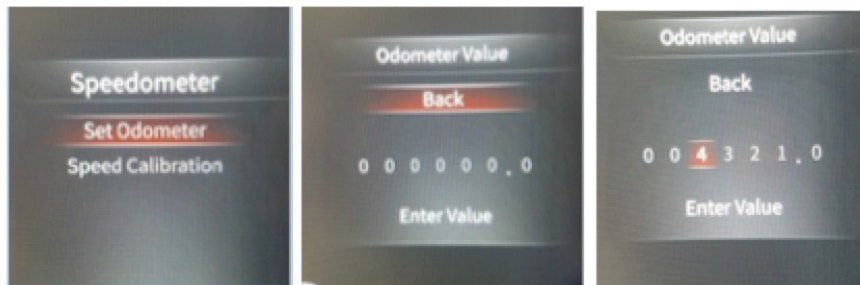

Once you have the complete odometer reading entered, scroll down to Enter Value and press Enter. The Dash will ask you "Are you sure?". You have the option to either press enter on OK, or scroll to Cancel and press Enter. This window will pop up 3 times. If you answer Ok all three times, the odometer is now permanently set and will only change by accumulating miles normally. **This cannot be changed again.**

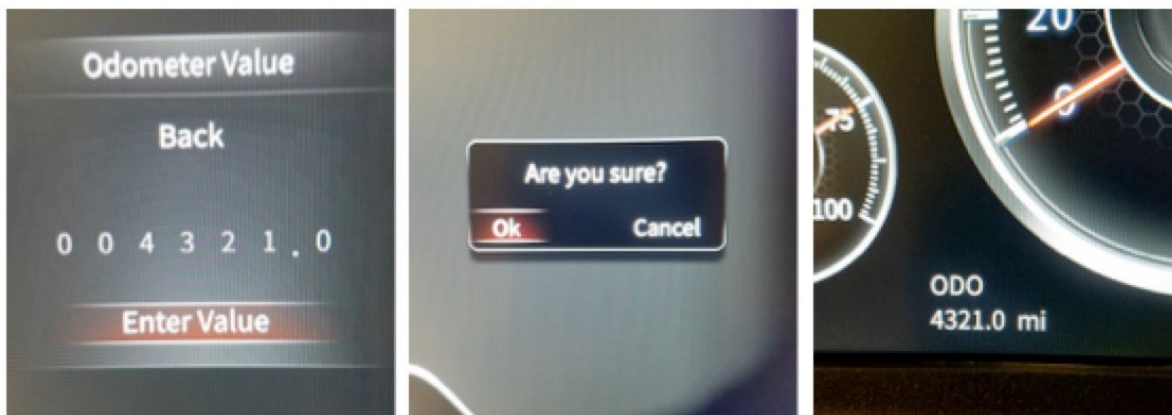

Trip Odometer: The InVision Digital Dash has the main odometer and two trip odometers. Both trips can be reset at any time by the user. To choose which Trip Odometer is displayed, enter the Main menu, scroll to Speedometer, and press Enter. You can choose which Trip is displayed and also reset (clear) either one. Scroll to the option you want to choose and press Enter. To Exit, scroll up to Back, and press Enter. Once you are back at the Main Menu, scroll to Close and press Enter.

System: This displays the versions of firmware the unit is equipped with.



Units: You have the option to choose either Imperial (Miles, MPH, °F and PSI) or Metric (Kilometers, KM/H, °C and BAR) units. To change the units of measure, enter the Main Menu, scroll to Units and press Enter. Scroll to either Imperial or Metric and press Enter. To exit, scroll up to Back, and press Enter. Once you are back at the Main Menu, scroll to Close and press Enter



Panel Cutout

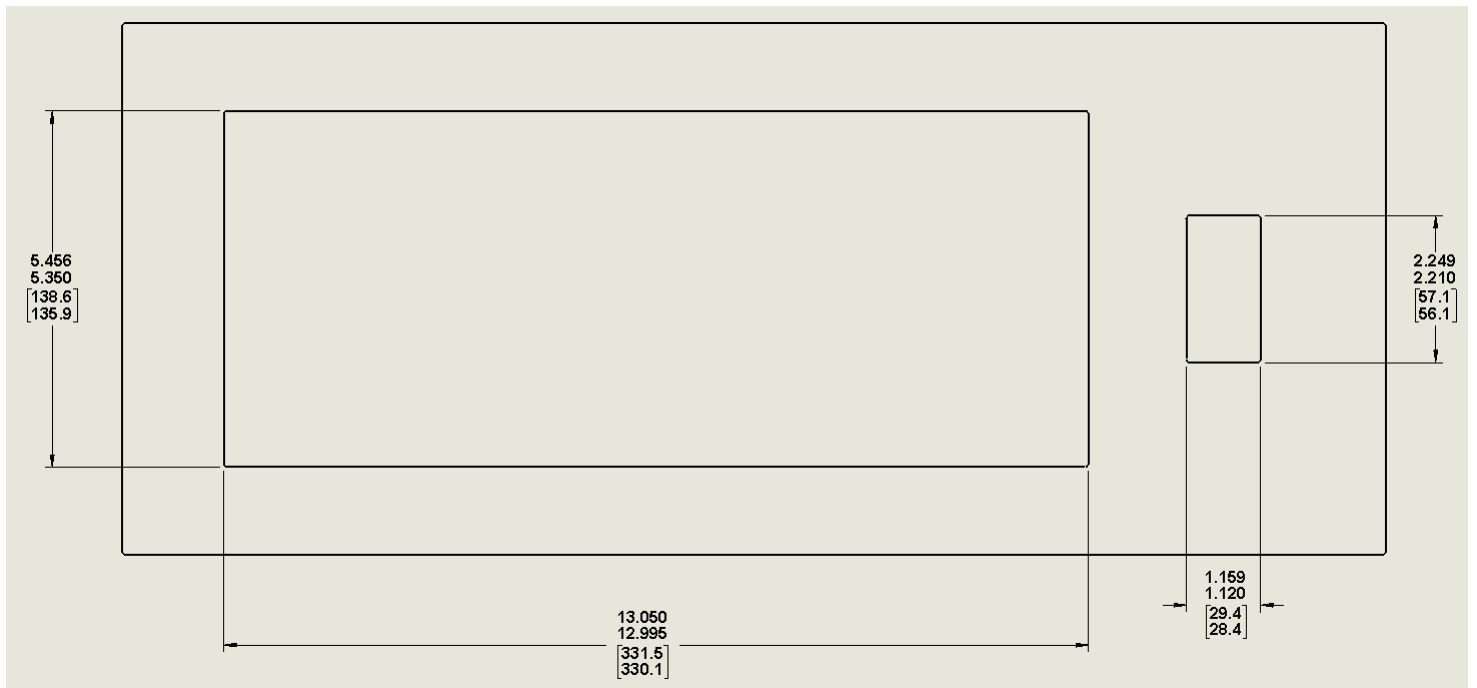

Layout Dimensions

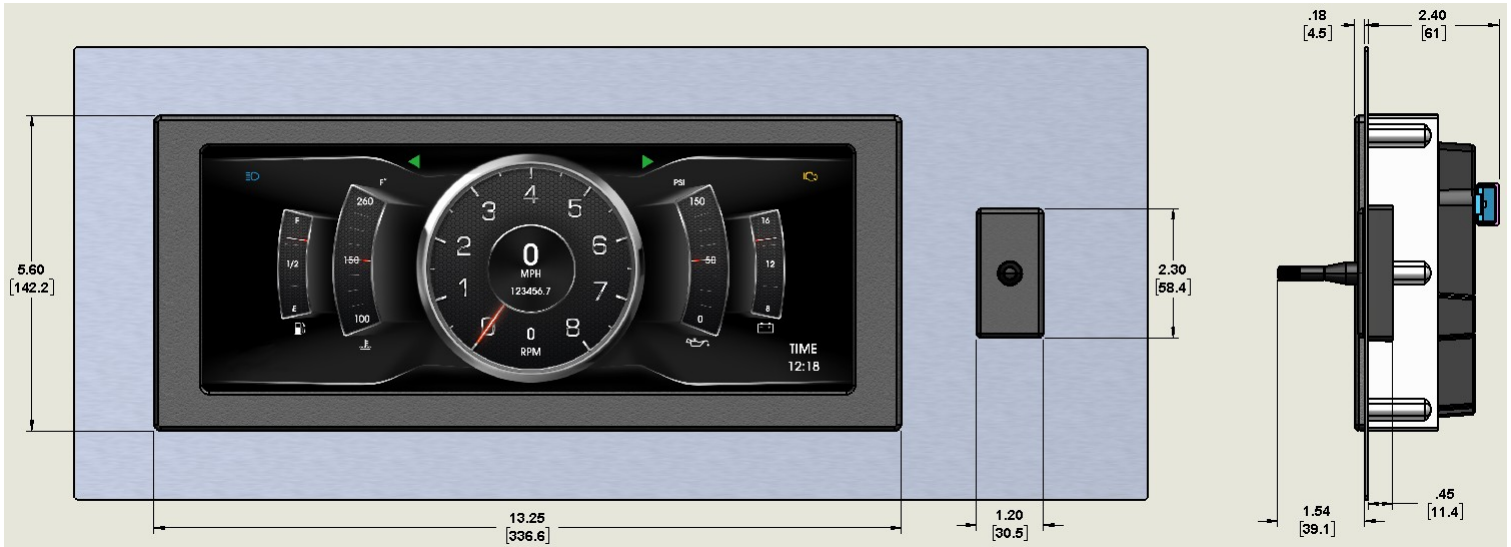

SERVICE

For service send your product to Auto Meter in a well packed shipping carton. Please include a note explaining what the problem is along with your phone number. If you are sending product back for warranty adjustment, you must include a copy (or original) of your sales receipt from the place of purchase.

12 MONTH LIMITED WARRANTY

AutoMeter Products, Inc. warrants to the consumer that all AutoMeter High Performance products purchased from an Authorized AutoMeter Reseller will be free from defects in material and workmanship for a period of twelve (12) months from date of the original purchase. Products that fail within this 12 month warranty period will be repaired or replaced at AutoMeter's option, when determined by AutoMeter that the product failed due to defects in material or workmanship. This warranty is limited to the repair or replacement of parts in the AutoMeter High Performance product and the necessary labor done by AutoMeter to effect the repair or replacement of the AutoMeter High Performance product. In no event shall AutoMeter's cost to repair or replace an AutoMeter High Performance Product under this warranty exceed the original purchase price of the AutoMeter High Performance Product. Nor shall AutoMeter Products, Inc. be responsible for special, incidental or consequential damages or costs incurred due to the failure of an AutoMeter High Performance Product. This warranty applies only to the original purchaser of the AutoMeter High Performance Product and is non-transferable. This warranty also applies only to AutoMeter High Performance Products purchased from an Authorized AutoMeter Reseller. All implied warranties shall be limited in duration to the said 12 month warranty period. Breaking the instrument seal, improper use or installation, accident, water damage, abuse, unauthorized repairs or alterations voids this warranty. AutoMeter disclaims any liability for consequential damages due to the breach of any written or implied warranty on all products manufactured by AutoMeter Products, Inc. For a comprehensive listing of Un-Authorized AutoMeter Resellers please visit www.autometer.com/autometerlocator/index/unauthorized.

FOR SERVICE SEND TO: AUTO METER PRODUCTS, INC. 413 W. Elm St., Sycamore, IL 60178 (866) 248-6356

For Email: Service@autometer.com